

**ADJUSTABLE SQUARE FLANGE JACK RECEPTACLE
WITH CYLINDRICAL CONTACT**

R125.414.120
SERIES SMA

Tenue du contact central par Resine Epoxy
(Resin Epoxy center-contact captivation)
(Rosin Epoxy zur Fixierung des innenleiters).

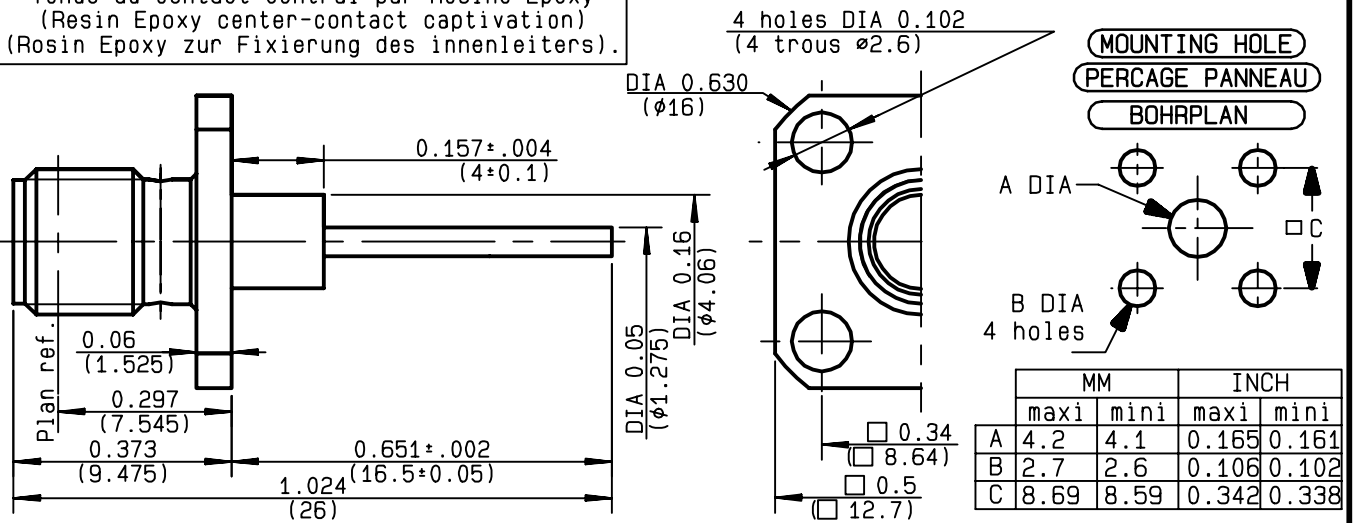

NOMINAL IMPEDANCE	50	Ω
FREQUENCY RANGE	0-18	GHz
TEMPERATURE RATING	-65/+165	°C
V.S.W.R	1.065	+ .0025 x F(GHz)Maxi
RF INSERTION LOSS	.07*	√F(GHz) dB Maxi
VOLTAGE RATING	500	Veff Maxi
DIELECTRIC WITHSTANDING VOLTAGE	1000	Veff Mini
INSULATION RESISTANCE	5000	MΩMini
HERMETIC SEAL	NA	Atm.cm ³ /s
LEAKAGE (pressurized only)	NA	
MECHANICAL DURABILITY	500	Cycles
WEIGHT	2.61	gr
SPECIFICATION		

CABLES :

OTHERS CHARACTERISTICS

*** COAXIAL TRANSMISSION LINE ONLY**

CABLE RETENTION	NA	N Mini
CENTER CONTACT RETENTION		
Axial force - mating end	27	N Mini
Axial force - opposite end	27	N Mini
Torque	2.8	cm.N Mini
RECOMMENDED TORQUES		
Mating	NA	cm.N
Panel nut	NA	cm.N
Clamp nut	NA	cm.N

CONNECTOR PARTS	MATERIALS	FINISH	(all values are given in micrometers)
BODY	STAINLESS STEEL	GOLD 0.5 OVER NICKEL 2	
OUTER CONTACT			
CENTER CONTACT	BERYLLIUM COPPER	GOLD 2.5 OVER NICKEL 2	
INSULATOR	PTFE	-	
GASKET		-	
OTHERS PIECES			

ISSUE	CREATION DATE	FILE PART-NUMBER
9843B00	09/05/1997	97-0104-717



ILLMER

The information given here is subject to change without notice.
Design changes may be in order to improve the product .

Connect to the future